

Product drawing

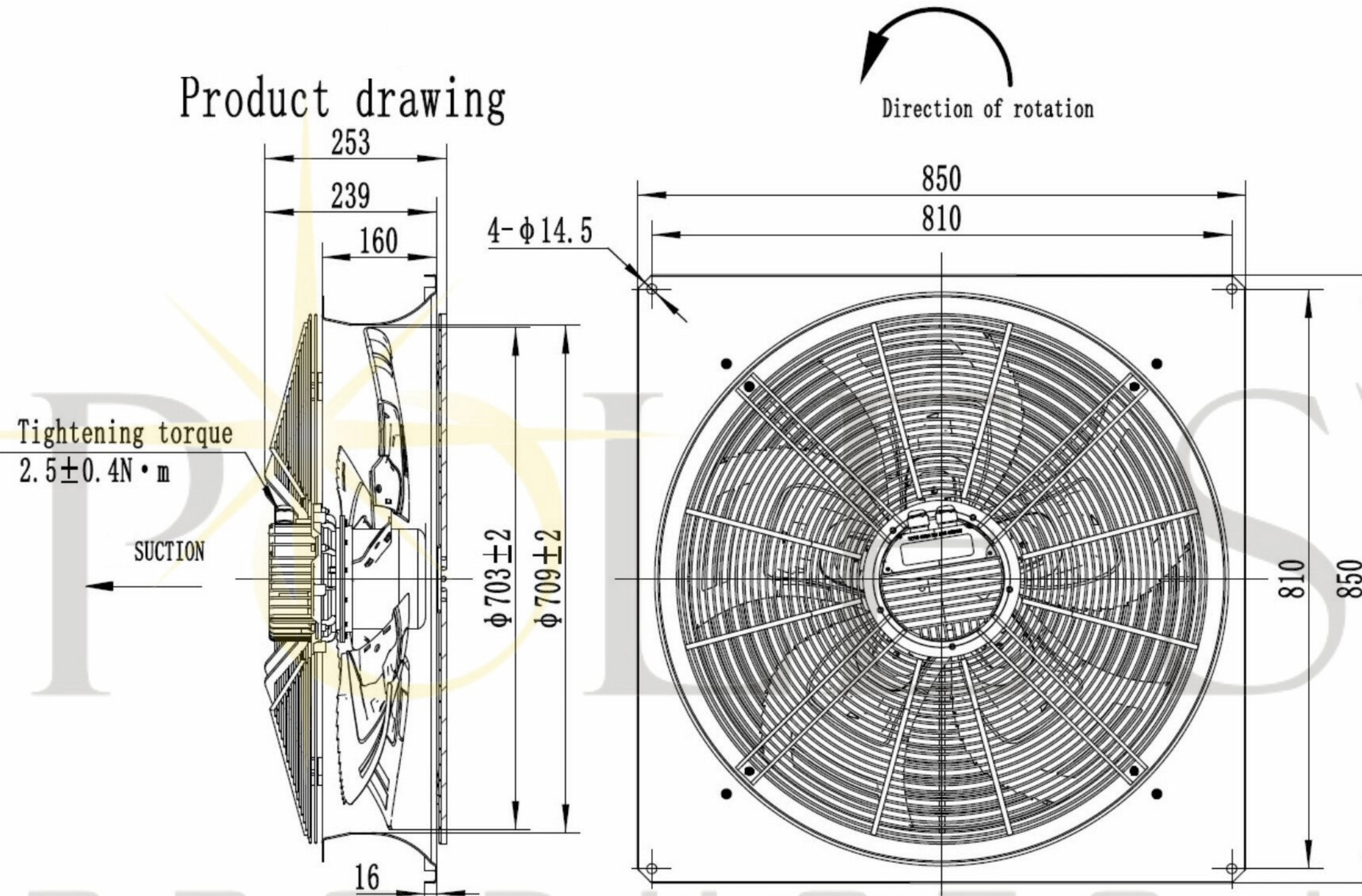

Tightening torque
2.5±0.4N·m

SUCTION

Direction of rotation

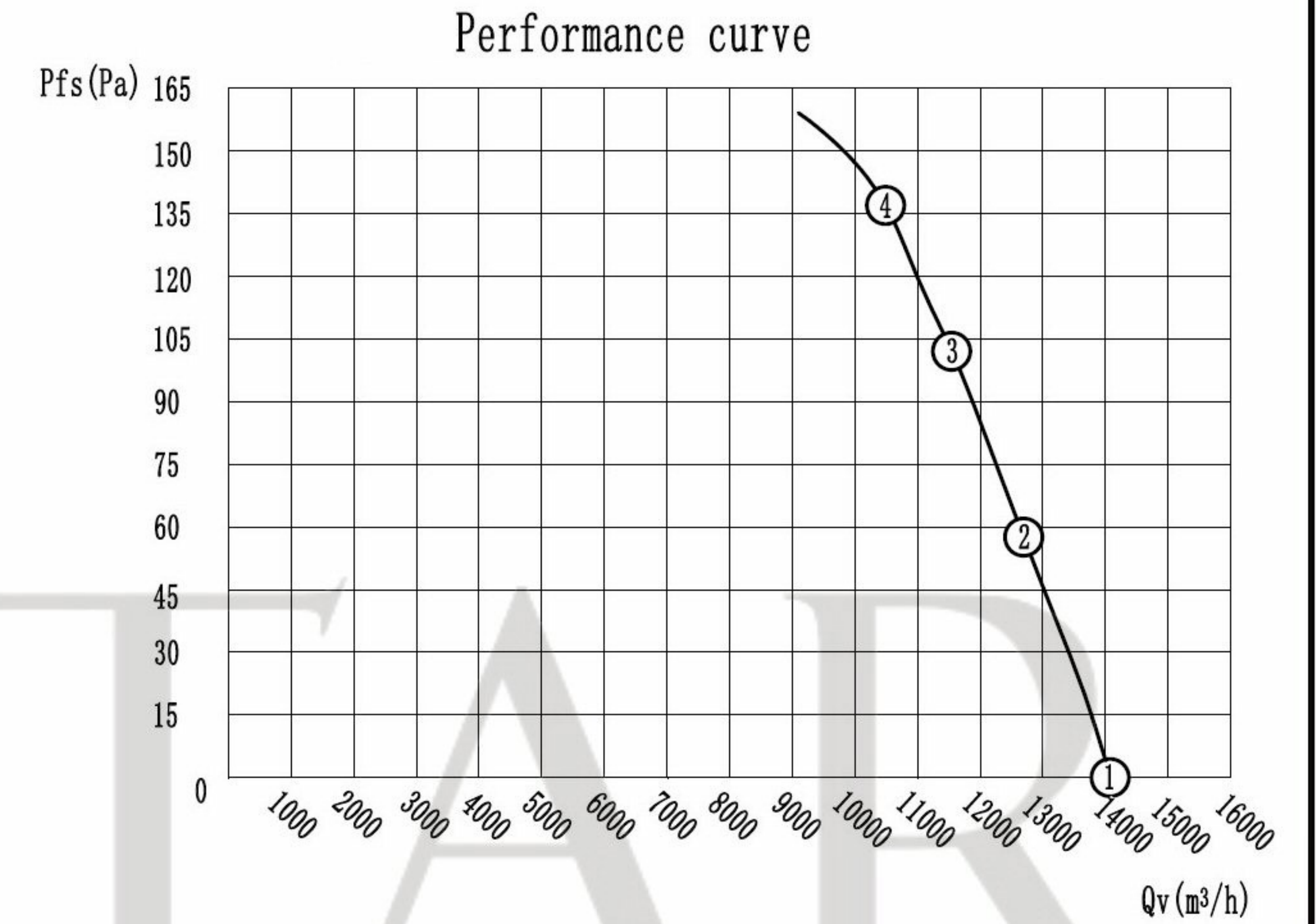

Measured values

	Pfs (Pa)	Current input (A)	Power input (W)	Speed (r/min)	Airflow (m³/h)	Note
①	0	1.19	694	1200	14076	
②	57	1.47	879	1200	12695	
③	102	1.62	973	1200	11545	
④	141	1.77	1066	1200	10285	MAX. EFF

Wiring diagram

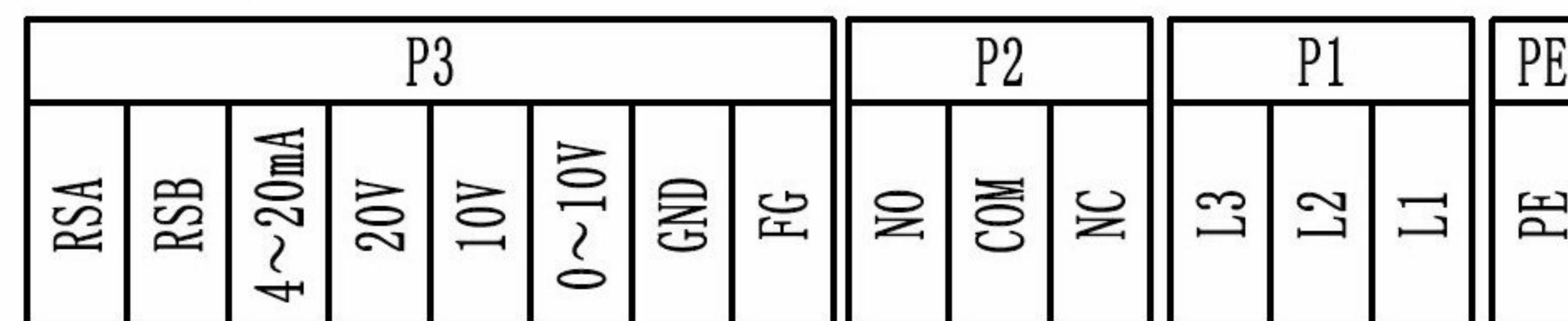

SPECIFICATION					
Motor	EC	Speed (RPM)	1200	Bearings	Ball
Voltage (V)	400	Motor Protection	Th.Prot.	Weight (Kg)	
Frequency (Hz)	50/60	Insulation Class	F	Noise dB(A)	76
Power In/Out (W)	694	Protection Class	IP54	ERP2015	
Current (A)	1.19	Operating Temp.	-25℃~+65℃	η: 37.95 (A,static) N= 44	

POLE STAR
PRODUCTS LIMITED

POLE STAR PRODUCTS LIMITED	
Product Code GMA3-710S-EC	
Projection Angle ± 3°	
	A4
	Scale:
	Sheet: 1 of