

Run on timer Instruction

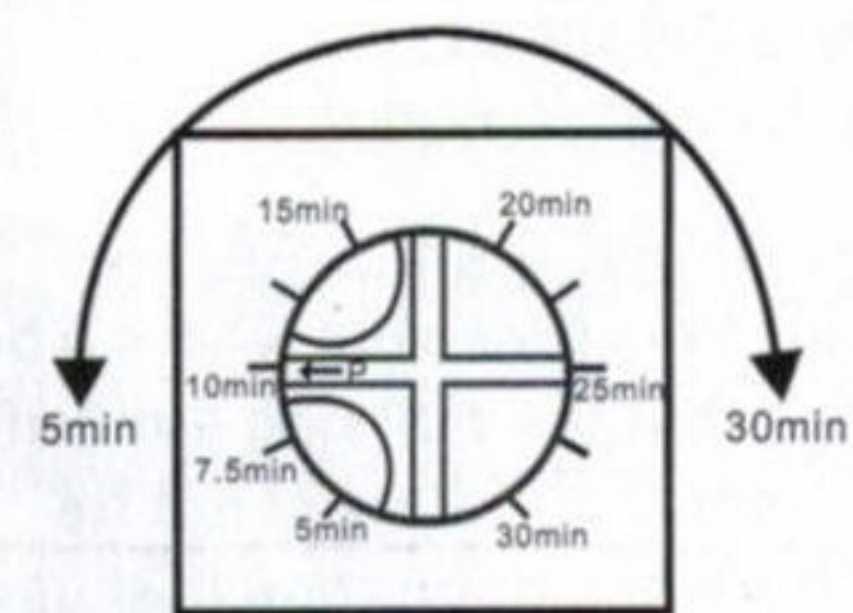

Run on timer

- Control model Description:
- 1) Run on time comes preset for 10min.
 - 2) Can adjust delay-time between 5 min and 30min.
 - 3) Arrow P Point to the delay-time.

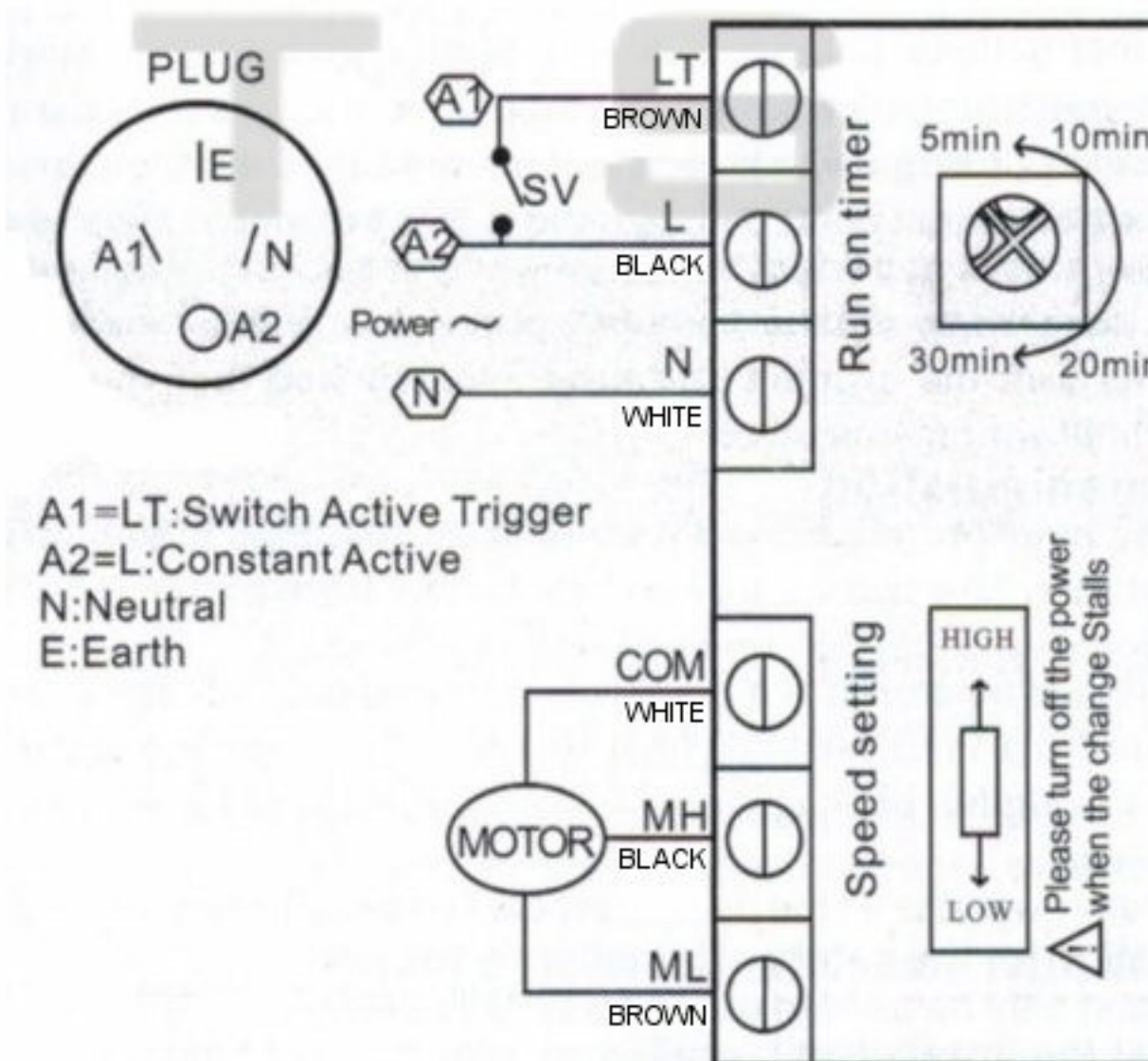

Speed Instruction

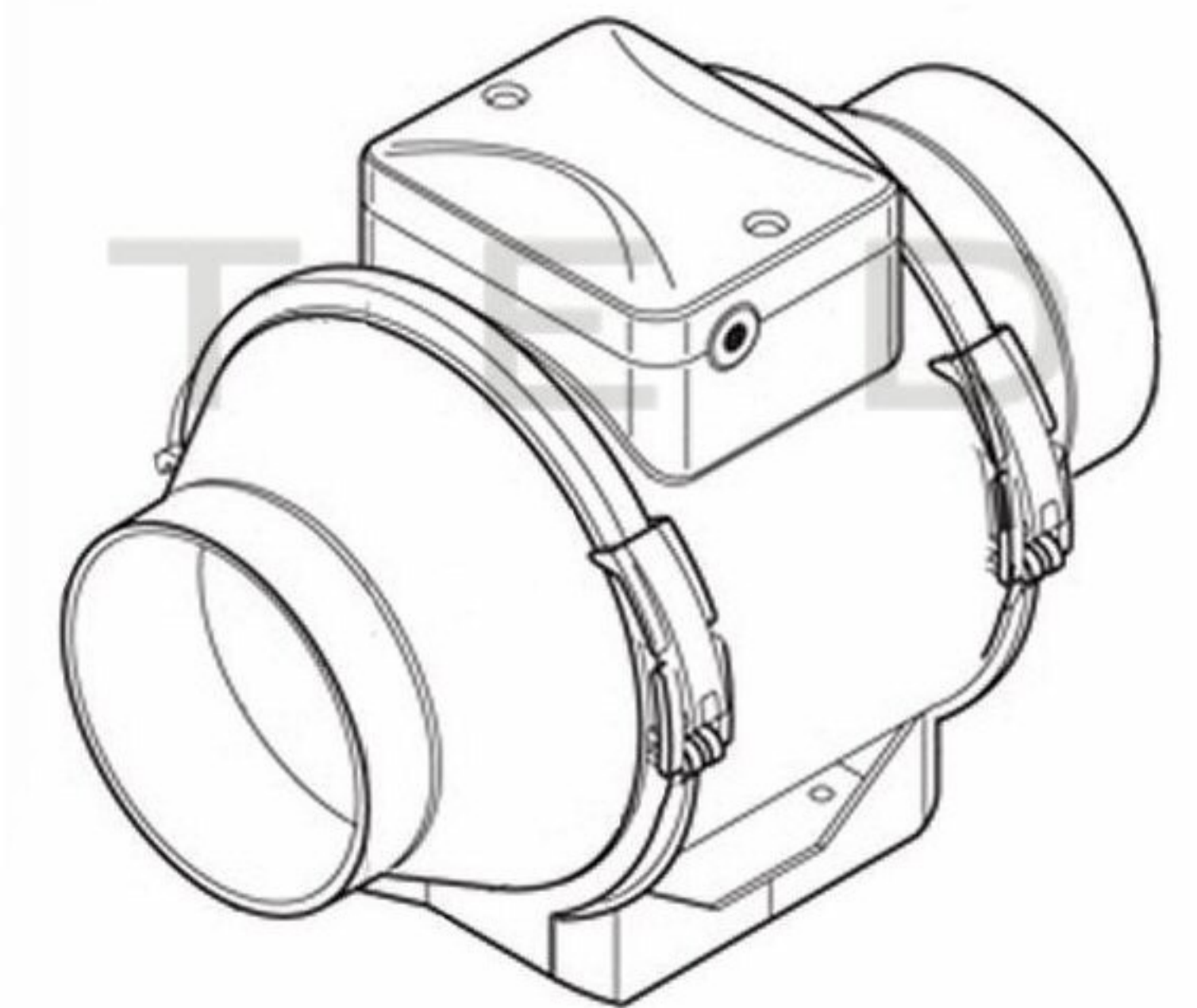
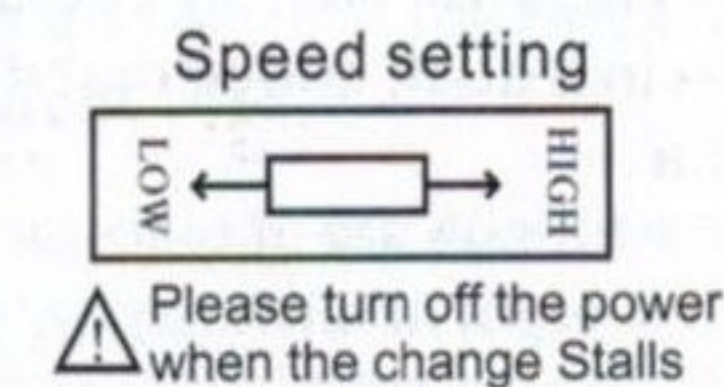

SPECIFICATION					
Motor	2-Speed	Speed (RPM)	2200	Bearings	Ball
Voltage (V)	230	Motor Protection	Imp.Prot.	Weight (Kg)	2.0
Frequency (Hz)	50/60	Insulation Class	B	Noise dB(A)	26/31
Power In/Out (W)	23/26	Protection Class	IP42	Amb. Temp(°C)	-20/+60
Current (A)	0.12	Volume (M /h)	165/198	Static Pres. (Pa)	131/156

POLE STAR
PRODUCTS LIMITED

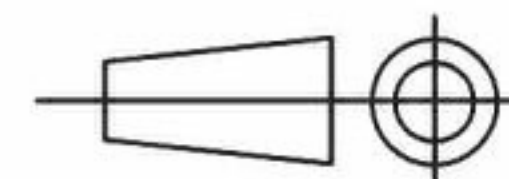
POLE STAR PRODUCTS LIMITED	
Product Code	MFF2-100-2VT
Projection Angle ± 3°	
	A4 Scale: Sheet: 1 of