

Run on timer Instruction

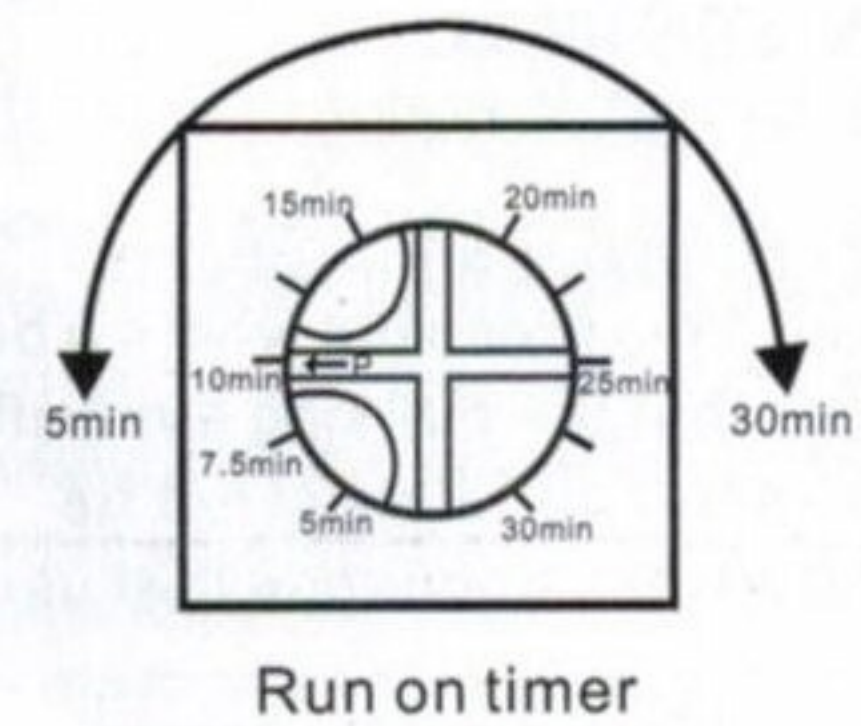

Control model Description:  
 1) Run on time comes preset for 10min.  
 2) Can adjust delay-time between 5 min and 30min.  
 3) Arrow P Point to the delay-time.

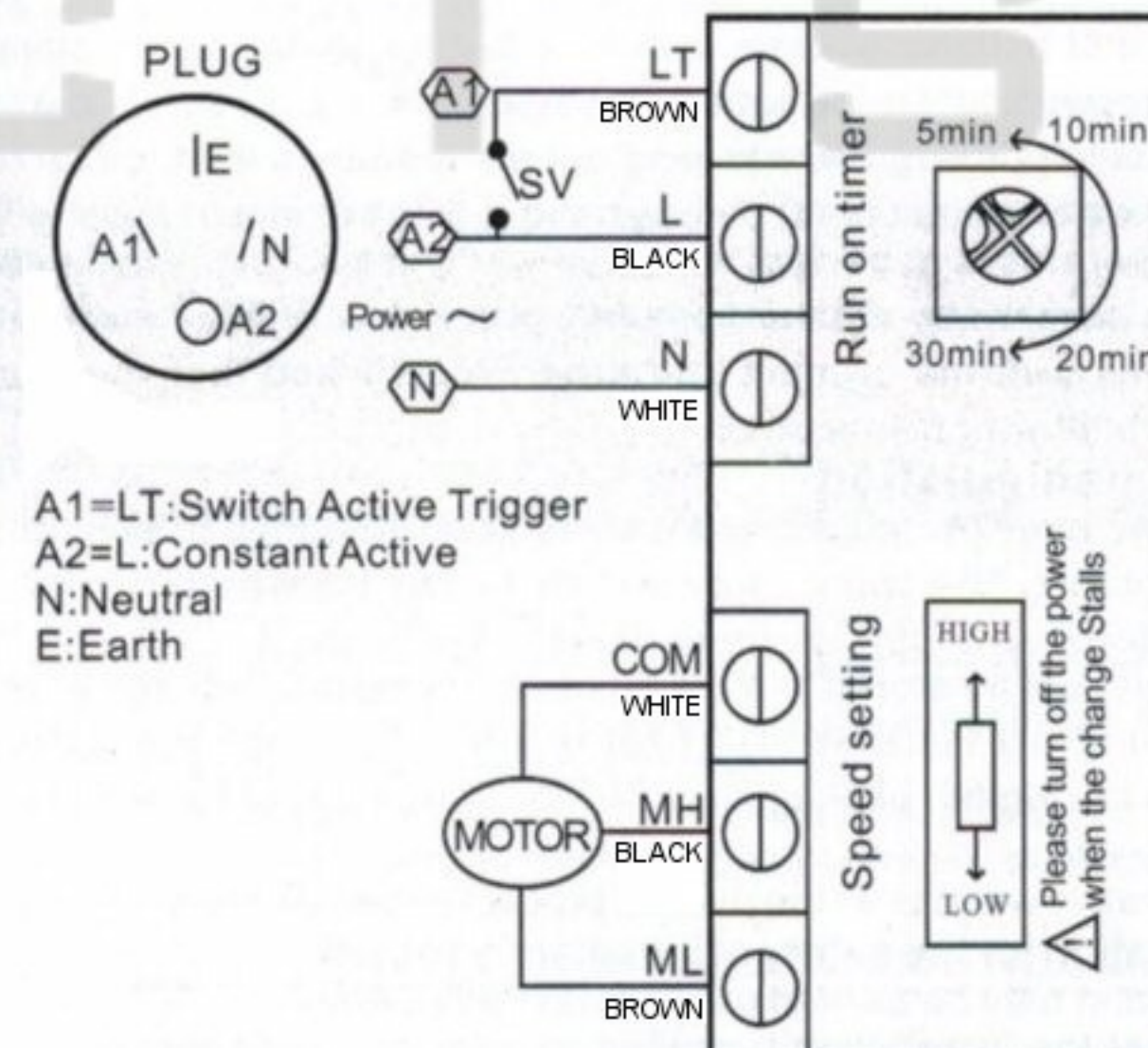

Speed Instruction

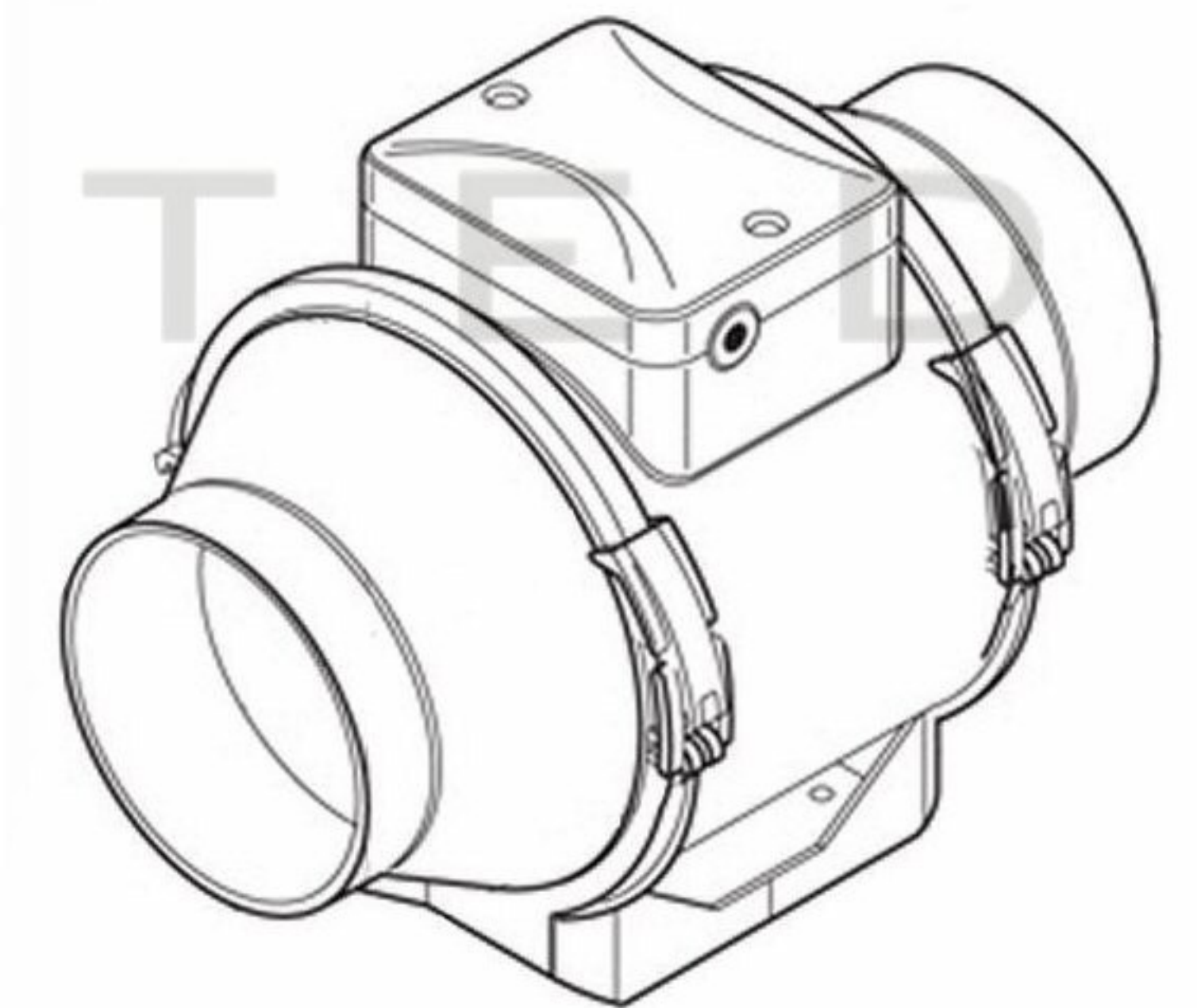
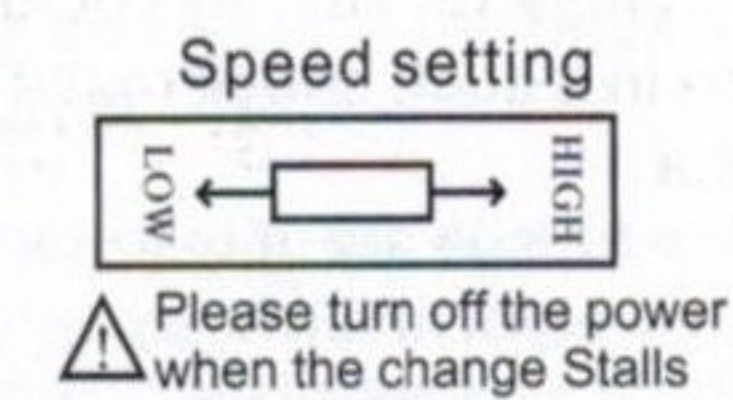

SPECIFICATION					
Motor	2-Speed	Speed (RPM)	2100/2600	Bearings	Ball
Voltage (V)	220/240	Motor Protection	Imp.Prot.	Weight (Kg)	1.8
Frequency (Hz)	50/60	Insulation Class	B	Noise dB(A)	26/31
Power In/Out (W)	20/35	Protection Class	IP44	Amb. Temp(°C)	-20/+60
Current (A)	0.17/0.28	Volume (M /h)	248/284	Static Pres. (Pa)	106/159

**POLE STAR**  
 PRODUCTS LIMITED

POLE STAR PRODUCTS LIMITED	
Product Code	<b>MFF2-125-2VT</b>
Projection Angle ± 3°	A4
	Scale: Sheet: 1 of