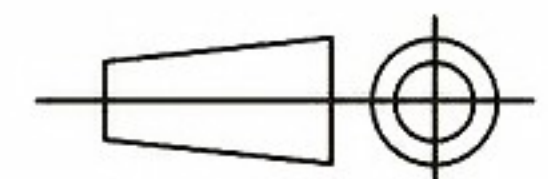

SPECIFICATION					
Motor	EC	Speed (RPM)	1500/2000	Bearings	Ball
Voltage (V)	115-230	Motor Protection	Th.Prot.	Weight (Kg)	
Frequency (Hz)	50/60	Insulation Class	Class II	Noise dB(A)	
Power In/Out (W)	22	Protection Class	IP65	Temp. Range (°C)	-40/+50
Current (A)					

POLE STAR
PRODUCTS LIMITED

POLE STAR PRODUCTS LIMITED	
Product Code ECTM20/2V	
Projection Angle ± 3°	
A4	
Scale: Sheet: 1 of	