

12 186 31

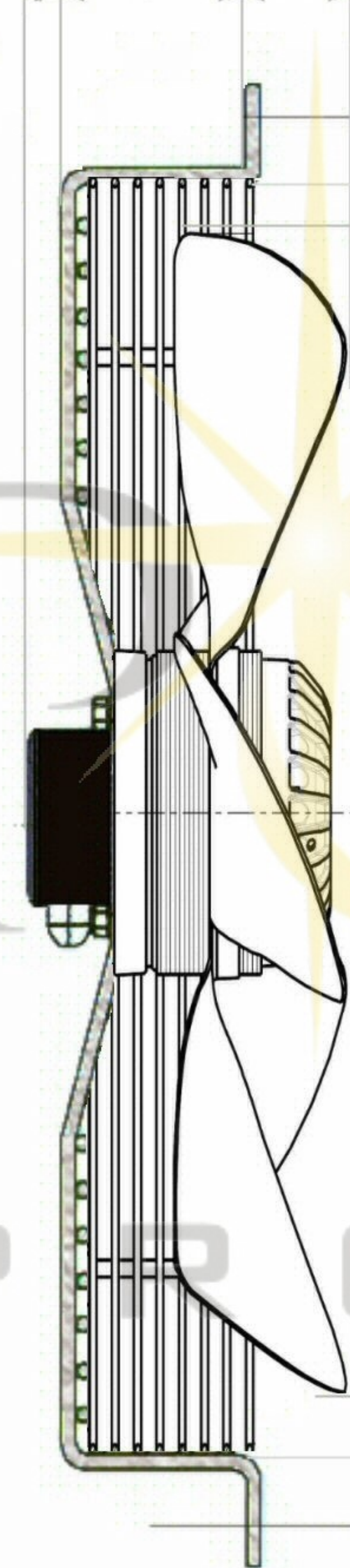

703 (+/- 5)

770 (+/- 2)

840

AIRFLOW DIRECTION

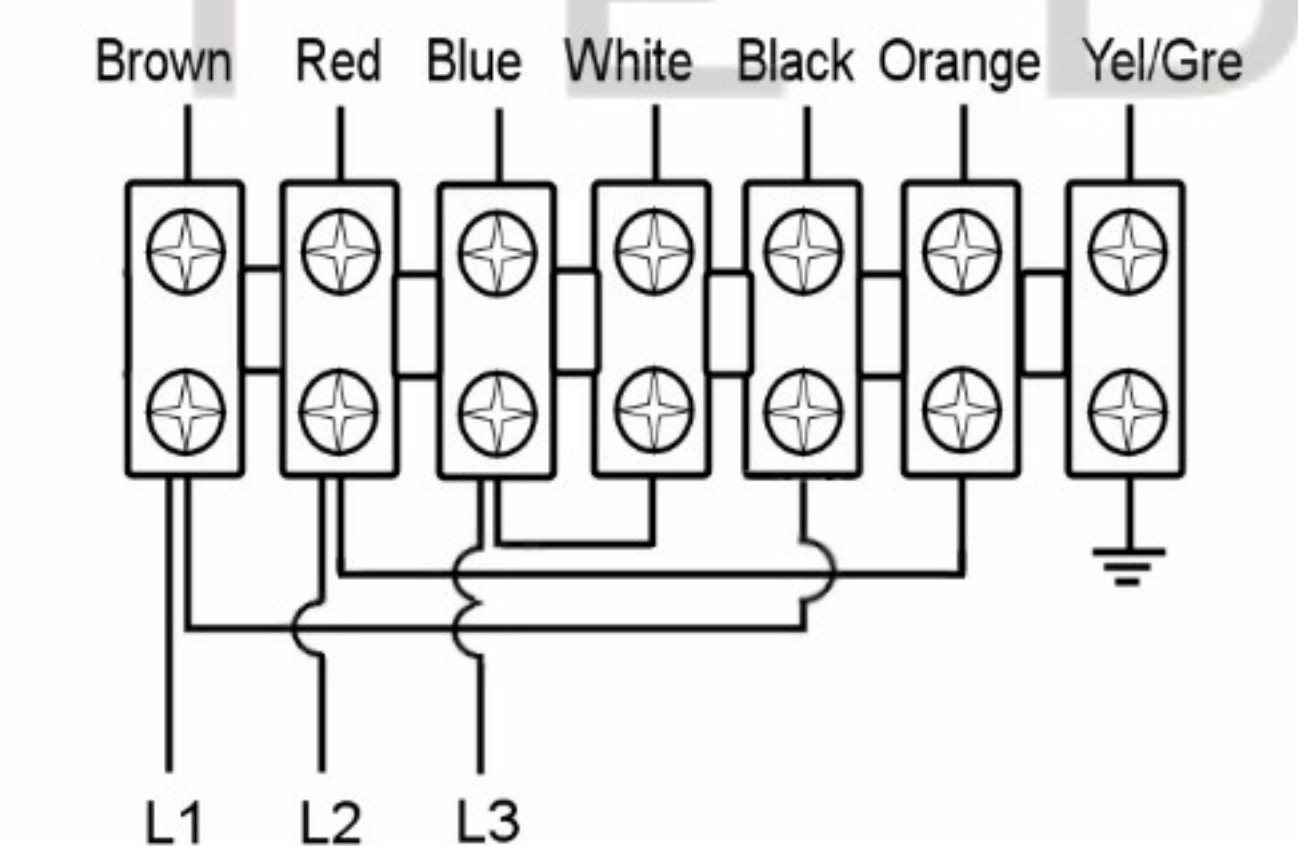
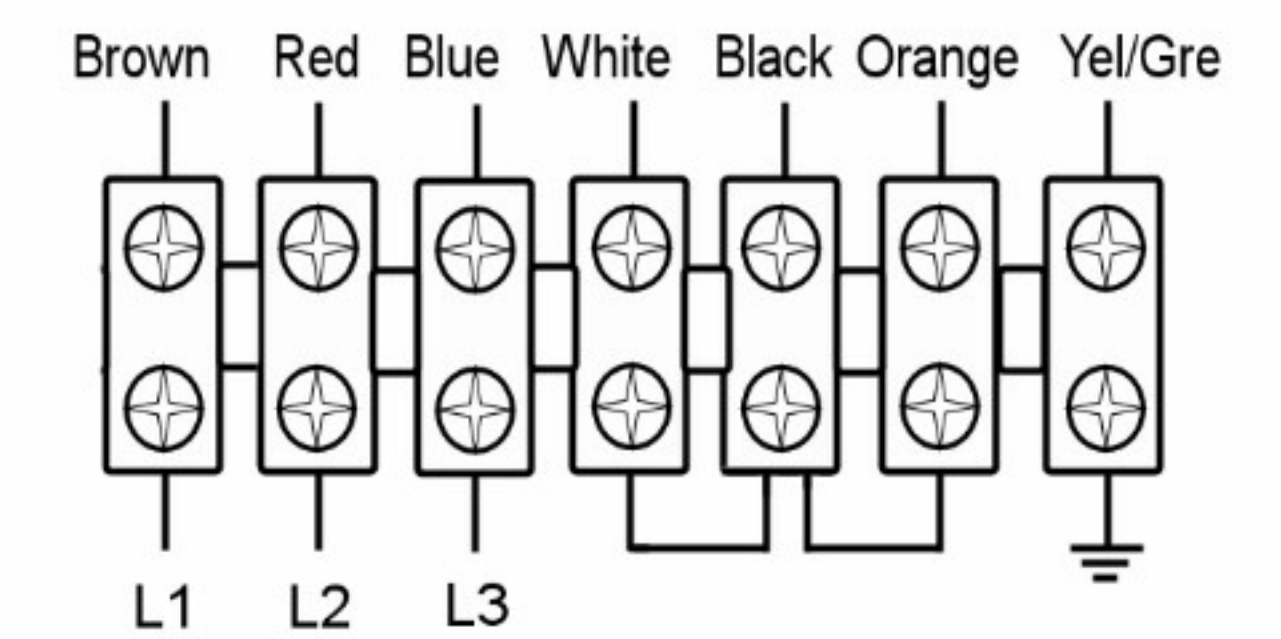
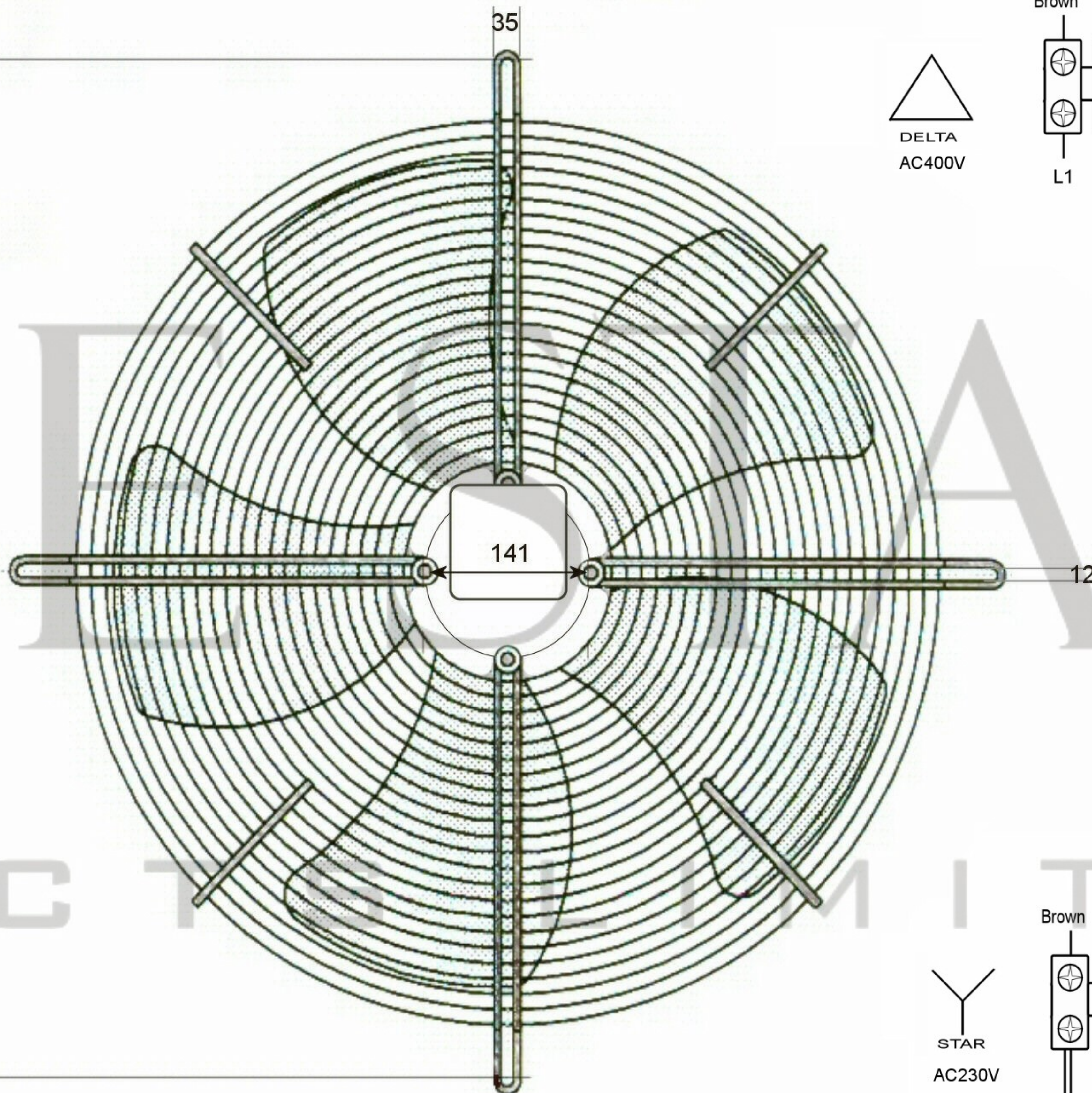

All measurements shown are in millimeters

| SPECIFICATION | Δ/Y | | | | |
|------------------|-----------|------------------|----------|--------------------------------|-----------------|
| Motor | 3Ph | Speed (RPM) | 920/760 | Bearings | Ball |
| Voltage (V) | 380 | Motor Protection | Th. Prot | Weight (Kg) | 23 |
| Frequency (Hz) | 50 | Insulation Class | B | Air Volume (M ³ /h) | 15300/ 12600 |
| Power In/Out (W) | 850/630 | Protection Class | IP54 | Noise Level (dBA) | 73/68 |
| Current (A) | 1.95/1.08 | Temp. Range | -30 +60 | Capacitor (Mf) | N/A |

POLE STAR
PRODUCTS LIMITED

| | |
|----------------------------|-------------|
| POLE STAR PRODUCTS LIMITED | |
| Product Code | |
| GMA3-710B6 | |
| Projection Angle | A4 |
| ± 3° | Scale: |
| | Sheet: 1 of |

