

6.3mm Faston terminals

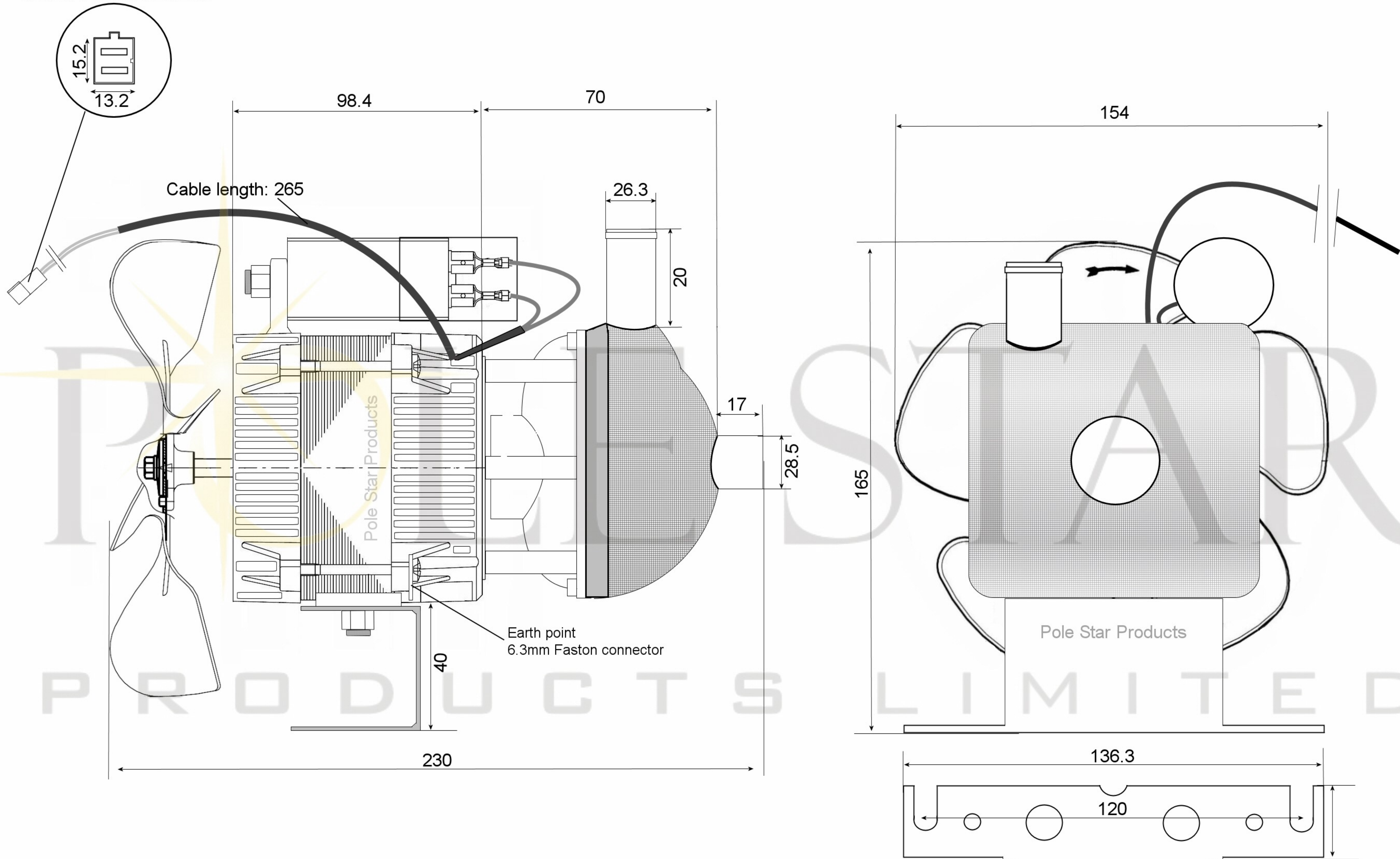
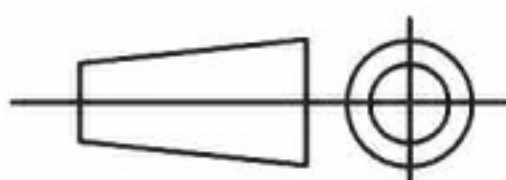

SPECIFICATION	All sizes shown are in millimeters				
Motor	PSC	Speed (RPM)	2948	Bearings	Ball
Voltage (V)	220/240	Motor Protection	Th.Prot.	Weight (Kg)	2.6
Frequency (Hz)	50/60	Insulation Class	F		
Power In/Out (W)	150	Protection Class	IP42		
Current (A)	0.7	Capacitor (MF)	5.0		

POLE STAR
PRODUCTS LIMITED

POLE STAR PRODUCTS LIMITED	
Product Code	IM-150-1
Projection Angle ± 3°	
	A4
	Scale:
	Sheet: 1 of