

ANTI-CLOCKWISE ROTATION

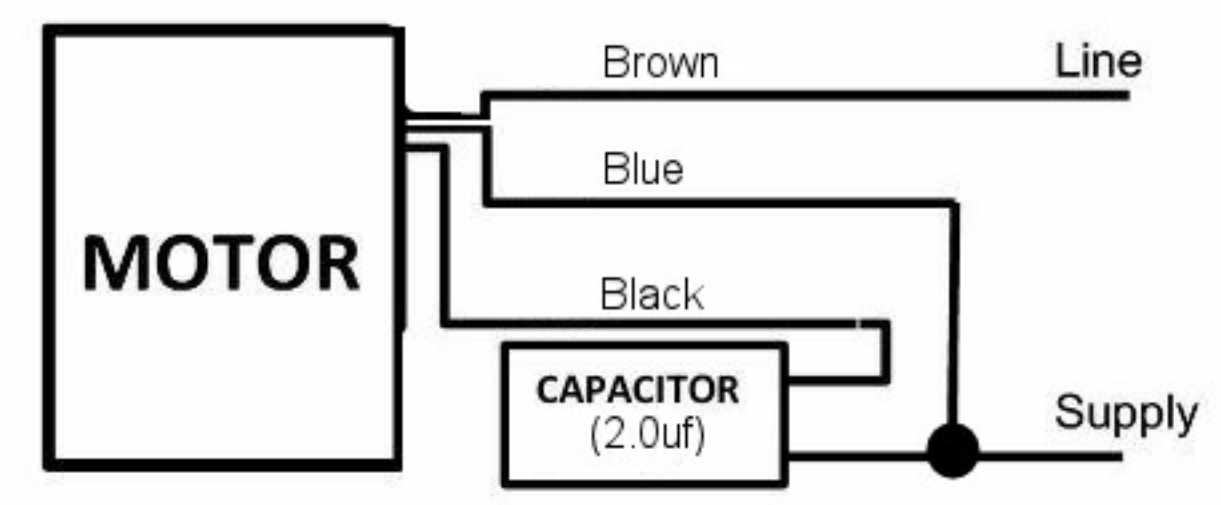

CLOCKWISE ROTATION

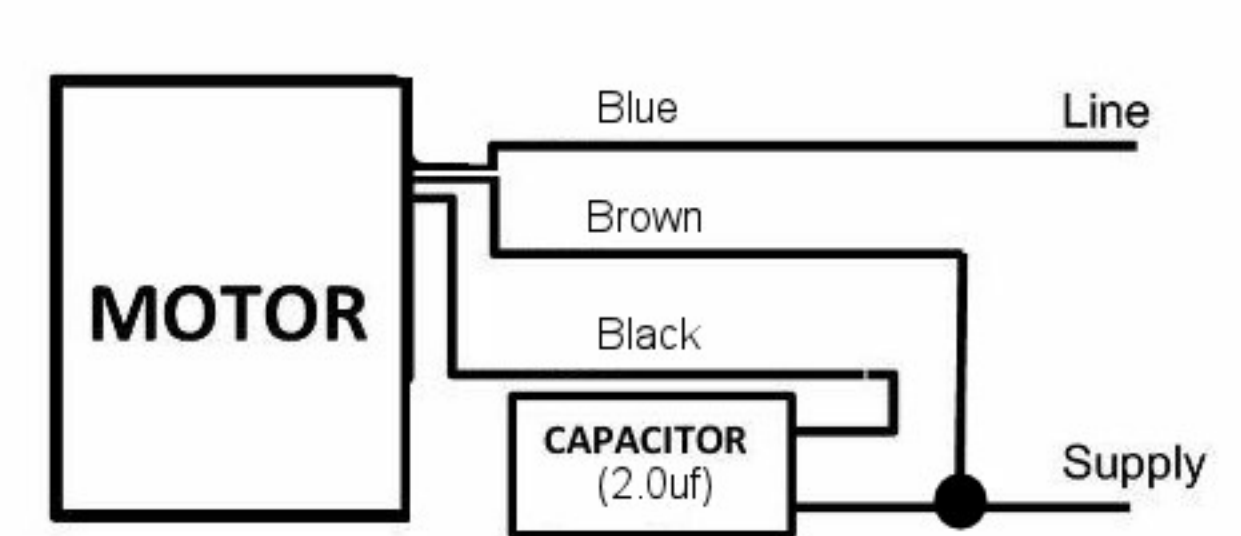

SPECIFICATION					
Motor	PSC	Speed (RPM)	1250	Bearings	Ball
Voltage (V)	220/240	Motor Protection	Th.Prot	Weight (Kg)	1.4
Frequency (Hz)	50	Insulation Class	B	Temp. Rating (°C)	-30/+60
Power Out (W)	30	Protection Class	IP42	Noise Level (dBA)	
Current (A)	0.3	Capacitor (Mf)	2.0	Pressure (Pa)	

POLE STAR
PRODUCTS LIMITED

POLE STAR PRODUCTS LIMITED	
Product Code	XRM1-FS30-1
Projection Angle	± 3°
	A4
	Scale:
	Sheet: 1 of